

Connecting your **DStv Explora** to the internet using the **DStv WiFi Connector** (manual setup)

If you want to connect your **DStv Explora** to your router in your home, it's best to use the **DStv WiFi Connector** if your router's in another room or when you don't want to run cables. WiFi signal must be available in the room your **DStv Explora** is in.

There are two options:

- **Automatic setup** (if your router has a WPS button)
- **Manual setup** (if your router does not have a WPS button, or if you are unable to set it up using the automatic setup)

These are the steps for the **MANUAL** setup

Step 1

- Place your computer close to your router.
- Turn WiFi off on your computer.
- Using the supplied power cable, connect one end into the USB port on your computer and the other end into the power input on the back of the **DStv WiFi Connector**.

- Using the supplied Ethernet cable, insert the one end into the Ethernet port on your computer. Now insert the other end into the Ethernet port on the back of the **DStv WiFi Connector**.

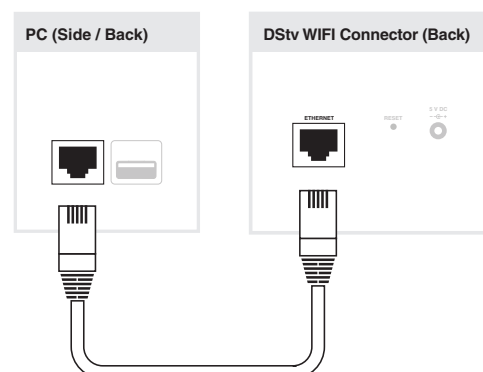
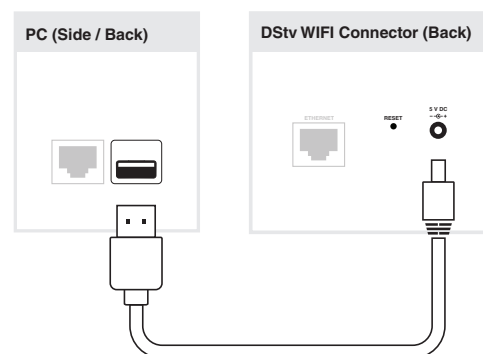

Step 2

- Open the web browser on your computer and type **http://dstvwifi.local/** into the address bar.

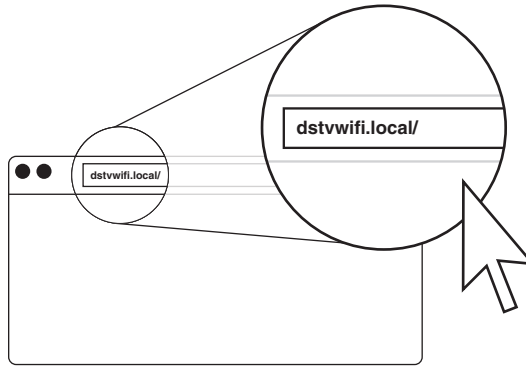

Step 3

- Select your router from the list, enter your wireless password and click on **“Connect.”**

TROUBLESHOOTING

- "WLAN" - network could not be found - your **DStv WiFi Connector** may be too far from your router or your router may be off. Please move the **DStv WiFi Connector** closer to your router and ensure that the router is switched on.
- "Wrong password" - you entered the wrong WLAN password. Please enter the correct password and try again.

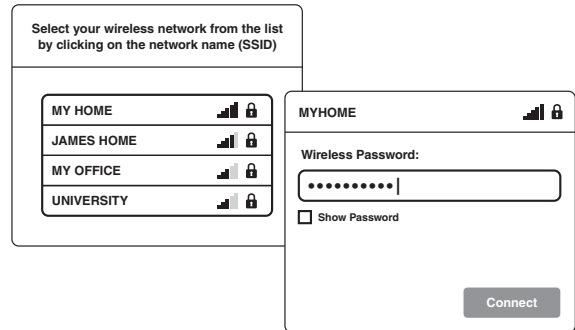

Step 4

- Disconnect the **DStv WiFi Connector** from your computer.

Step 5

- Using the supplied Ethernet cable, insert the one end into the green Ethernet port on the back of the **DStv Explora**. Now insert the other end into the Ethernet port on the back of the **DStv WiFi Connector**.

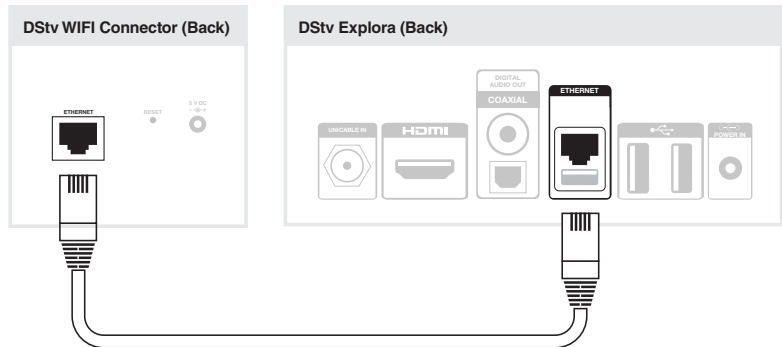

Step 5 (cont.)

- Using the supplied power cable, connect one end into the USB port on the back of the **DStv Explora** and the other end into the power input on the back of the **DStv WiFi Connector**.

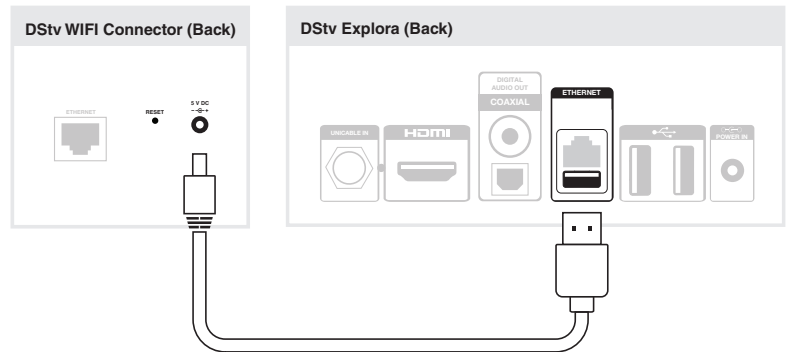

- The Power LED on the front of the **DStv WiFi connector** should light up (*solid amber*) and then change to *solid white*, confirming the **DStv WiFi Connector** has power.

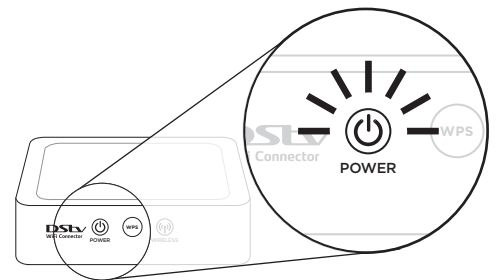

Step 6

- Wait two minutes.
- The Wireless LED on the front of the **DStv WiFi Connector** should light up (*solid white*) once an internet connection has been established.

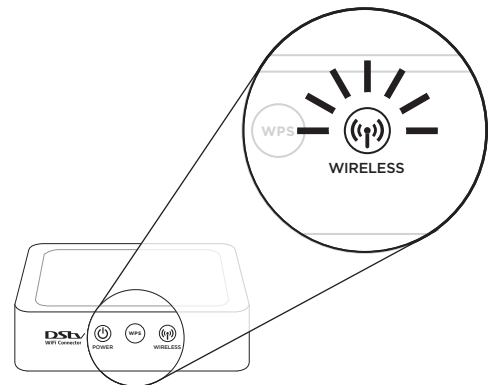

TROUBLESHOOTING

- If the Wireless LED on the front of the **DStv WiFi Connector** is solid amber, the internet connection is weak. To fix this, move the **DStv WiFi Connector** closer to the router and try again.

Step 7

You can now check the connectivity on your **DStv Explora**.

- Press **HELP** on the remote.
- Select **"Tools"**.
- Select **"Connectivity Checker"** and press **OK**.

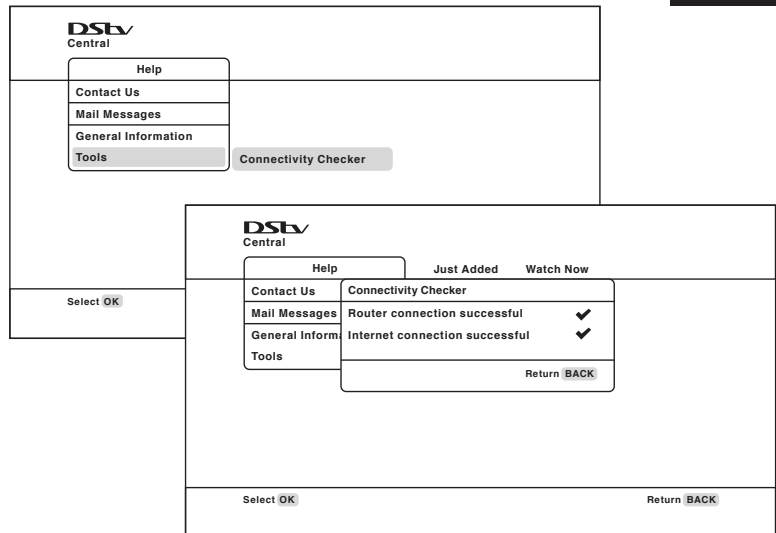

Step 8

The default setting for all Connected Services on your **DStv Explora** is set to "Off". You can manually select which of the services you want enabled.

- Press the blue **DStv** button.
- Select **"Settings"**.
- Select **"User Preferences"**.
- Select **"Connected Services"**.
- You can then set each of the Connected Services **"On"** or **"Off"** individually.
- Press **BACK** to save your setting.

